

NIVOFIX®

See Vibrachoc
metallic range
V43 - V44
V45 - V46



DESCRIPTION

The NIVOFIX® mount is an adjustable equipment foot comprising a circular disc bonded to a protected rubber base. An adjustment screw permits the levelling.

The rubber base has anti-slip ridges.

OPERATION

The design of the NIVOFIX® mount gives the following basic characteristics :

- accurate adjustment of the mount to correct the equipment's seating (adjustment screw, correction of altitude);
- absorbs high frequency vibrations;
- corrosion resistant (nitrile elastomer, protective shroud, galvanised metallic parts);
- anti-slip sole (no need to fix).

Advantages

- Speed of fixing.
- Simple removal of the equipment.
- No shimming.

DIMENSIONS

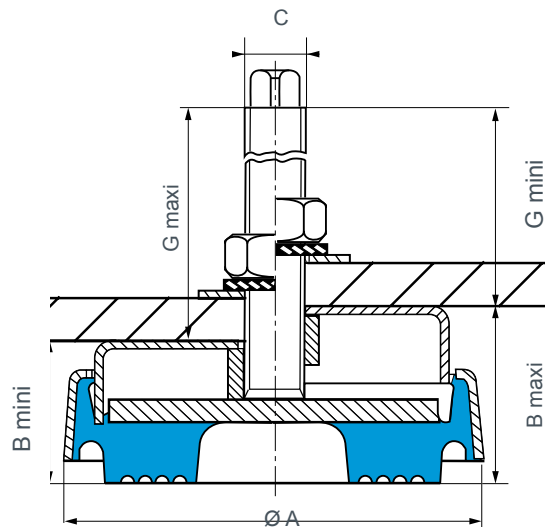

Reference Stainless steel	Reference Steel	Ø A (mm)	B (mm)			C	G (mm)		Stud lenght (mm)	Weight (g)
			B max. = B min. + adjustment				min.	max.		
530815	530810	65	31,5	26,5	5	M12	105	110	128	280
530825	530820	88	46	33	13	M16	114	127	150	690
530835	530830	133	58	46	12	M20	130	142	173	1 820
-	530840	200	70	58	12	M24	145	157	195	5 250
-	530850	260	83	65	18	M24	158	176	215	10 000

See the current price list for availability of items.

OPERATING CHARACTERISTICS

Reference	Nominal static load min. - max. (daN)	Deflection (mm)
530810	100 - 600	1 - 3,5
530815	100 - 600	1 - 3,5
530820	325 - 1 300	2 - 4
530825	325 - 1 300	2 - 4

Reference	Nominal static load min. - max. (daN)	Deflection (mm)
530830	650 - 2 600	2 - 4
530835	650 - 2 600	2 - 4
530840	1 500 - 6 000	1,5 - 3
530850	3 000 - 12 000	2 - 4

APPLICATIONS

NIVOFIX® mounts are used for all equipment requiring height adjustment.

Equipment already using NIVOFIX® mounts :

- Vertical mill
- Mortiser
- Multichuck drill
- Sheet metal bender
- Polisher
- Press
- Plane
- Horizontal mill
- Lathe
- Gear cutter
- Textile machinery
- Packaging machine
- Test equipment
- Printing press